

DIY HALF RACK

SQUAT RACK/BENCH PRESS

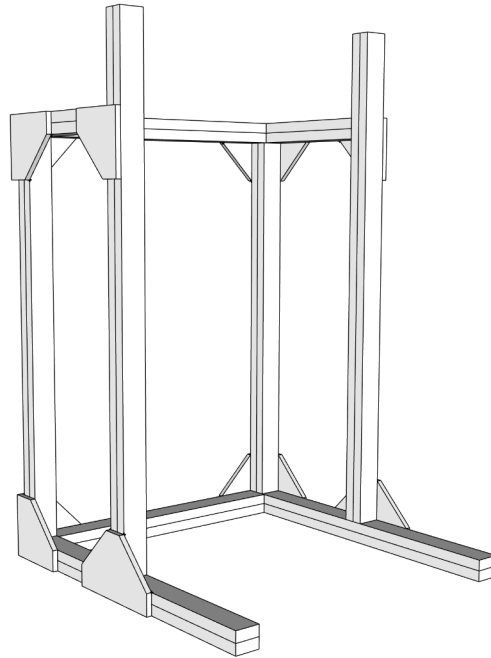

I CUT ALL OF MY PIECES OUT OF 2X4'S AND MADE EACH POST 2 LAYERS THICK. EACH OF MY 3/4" PLYWOOD BRACKETS EXTEND 6" ON EITHER SIDE OF THE JOINT

CUT LIST

- 4 @ 48" (BOTTOM)
- 4 @ 60" (BACK VERTICAL)
- 4 @ 72" (FRONT VERTICAL)
- 4 @ 19.5

